

# Manual for Modbus Sensor

- [USER GUIDE FOR TRIAXIAL VIBRATION SENSOR - MBRTU-V3A](#)

# USER GUIDE FOR TRIAXIAL VIBRATION SENSOR - MBRTU-V3A

MBRTU-V3A-MN-EN-01

JUN-2026

*This document is applied for the following products*

SKU	MBRTU-V3A	HW Ver.	1	FW Ver.	1
Item Code	V3A-06-485-01	Triaxial vibration sensor, RS485 Modbus RTU Output, 6KHz Ultra-low Noise MEMS sensor with Temperature, M6 screw, M12-male 4pin connector, IP67			
	V3A-06-485-02	Triaxial vibration sensor, RS485 Modbus RTU Output, 6KHz Ultra-low Noise MEMS sensor with Temperature, M6 screw, M12-female 4pin connector, IP67			

## 1. Functions Change Log

HW Ver.	FW Ver.	Release Date	Function Change
1	1	13 Jun 26	Initial firmware

## 2. Introduction

MBRTU-V3A vibration sensor is 6KHz Ultra-low Noise MEMS sensor with temperature. This sensor utilizes digital temperature sensor delivers high accuracy measurement. Output is RS485 Modbus RTU for easily integrating with any PLC, controller, SCADA, BMS or IoT gateway.

- Digital sensor technology;
- High accuracy;
- Standard RS485 Modbus RTU output;
- Plug & Play.



# 3. Specification

Specification	Values
Sensor Type	Ultra-low noise 3-axis digital MEMS vibration sensor
Measurement axes	X, Y, Z
Frequency Bandwidth	6KHz, +/- 3dB
Acceleration range	+/- 16G
Sampling rate	26.667 kHz
Resolution	16 bit
Sensitivity	0.488 mg/LSB
Sensitivity tolerance	±2% typ. at 25°C
Sensitivity drift	±1% typ. over temperature
Integrated noise, 0-6.3 kHz	X/Y 6 mg RMS, Z 8.7 mg RMS
Integrated noise, 0-1 kHz	X/Y 2.4 mg RMS, Z 3.5 mg RMS
Surface temperature measurement	-40 .. + 85 oC with +/- 0.5 oC accuracy typ. after calibration
Measurement Output	8 vibration values for each axis + surface temperature
Communication Interface	RS485, ModbusRTU, baud rate of 11520 bps, none parity
Power Supply	7..36VDC max 200mA, Surge Protection for Power supply and RS485 lines
Housing	Inodized Aluminium, IP67
Mounting	M6x35 through-bolt, optional M5/M4 sleeve, optional magnetic adapter
Connector	M12 male 4-pin, A-coded for V3A-06-485-01 and M12 female 4-pin, A-coded for V3A-06-485-02
Working temperature	-40 .. + 85 oC
Dimension	46 x 42mm (without M12 connector)
Weight	< 250 grams

# 3. Product components



## 4. Dimensions

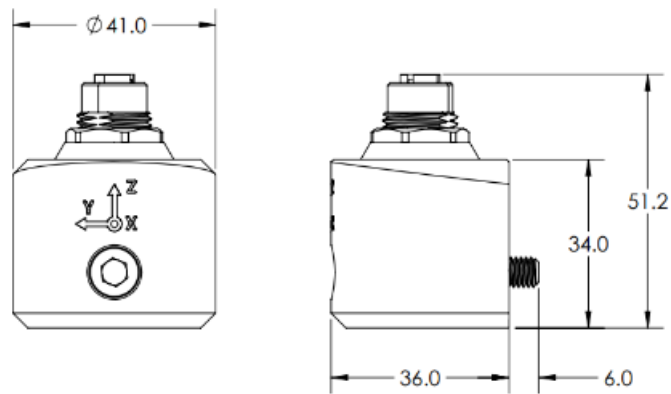

## 5. Wiring

### 5.1 Electrical connector

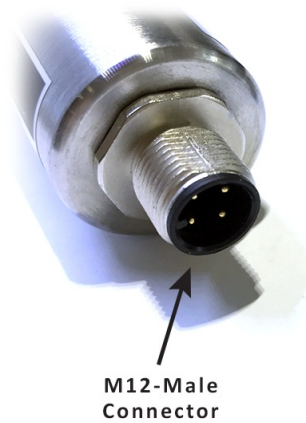

## 5.2 Pinout

**Because the sensor uses an M12 electrical connector, please look closely at the pinouts of the M12 electrical connector as shown below.**

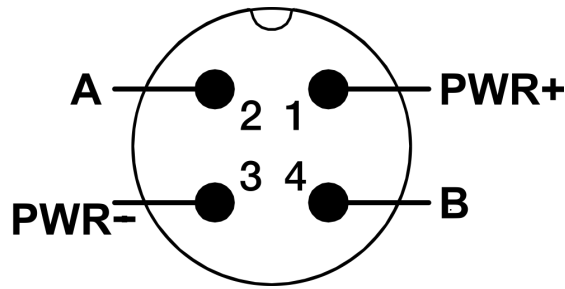

**A - B:** RS485/ModbusRTU Output

**PWR+:** Power supply 7..48VDC

**PWR-:** Ground, 0VDC

## 6. Configuration

### 6.1 Configuration steps

1. Connect A pin of sensor M12 connector to RS485+ of Modbus master device (PC, PLC...) and connect B pin of M12 connector to RS485- of Modbus master device (PC, PLC...)
2. Connect PWR+ and PWR- to 7-48 VDC power supply
3. Use Modbus software to read the sensor with Modbus function of 3 and to write with Modbus function of 16. Details are in memory map registers section

### 6.2 Memory map registers

Modbus Register (Dec)	Modbus Register (Hex)	Func Code (Read)	Func Code (Write)	# Reg	Description	End-user Default	Format	Comment
0	0	3	None	2	FW_CODE	V3A	string	Firmware code
2	2	3	None	4	FW_VERSION	1Fmmdd	string	Firmware version mmdd = month / day
6	6	3	None	2	HW_VERSION	1H	string	Hardware version v1
8	8	3	None	2	X_VELOCITY_RMS_A		float	RMS Velocity of band A, unit of mm/s, for X-axis
10	A	3	None	2	X_ACCELERATION_RMS_B		float	RMS Acceleration of band B, unit of m/s <sup>2</sup> , for X-axis
12	C	3	None	2	X_CREAST_FACTOR_B		float	Crest factor of band B, for X-axis
14	E	3	None	2	X_KURTOSIS_B		float	Kurtosis factor of band B, for X-axis
16	10	3	None	2	X_ACCELERATION_PEAK_B		float	Peak Acceleration of band B, unit of m/s <sup>2</sup> , for X-axis
18	12	3	None	2	X_CREAST_FACTOR_C		float	Crest factor of band C, for X-axis

20	14	3	None	2	X_KURTOSIS_C		float	Kurtosis factor of band C, for X-axis
22	16	3	None	1	X_SHOCK_COUNT		uint16	Counter for shock events captured, a shock event is determined by exceeding shock threshold (could be config by SHOCK_THRESHOLD registers), for X-axis
23	17	3	None	1	X_TEMPERATURE_X10		int16	Temperature = TEMPERATURE_X10 divide by 10, for X-axis
24	18	3	None	2	X_SCALE_FACTOR_A		float	Scale factor A for velocity and acceleration values, for X-axis
26	1A	3	None	2	X_SENSOR_SENSITIVITY		float	Sensor sensitivity, unit of mV/g, for X-axis
28	1C	3	None	2	X_SHOCK_THRESHOLD		float	Shock threshold to detect/count shock event, unit of G, for X-axis
30	1E	3	None	2	Y_VELOCITY_RMS_A		float	RMS Velocity of band A, unit of mm/s, for Y-axis
32	20	3	None	2	Y_ACCELERATION_RMS_B		float	RMS Acceleration of band B, unit of m/s <sup>2</sup> , for Y-axis
34	22	3	None	2	Y_CREST_FACTOR_B		float	Crest factor of band B, for Y-axis
36	24	3	None	2	Y_KURTOSIS_B		float	Kurtosis factor of band B, for Y-axis
38	26	3	None	2	Y_ACCELERATION_PEAK_C		float	Peak Acceleration of band B, unit of m/s <sup>2</sup> , for Y-axis
40	28	3	None	2	Y_CREST_FACTOR_C		float	Crest factor of band C, for Y-axis
42	2A	3	None	2	Y_KURTOSIS_C		float	Kurtosis factor of band C, for Y-axis
44	2C	3	None	1	Y_SHOCK_COUNT		uint16	Counter for shock events captured, a shock event is determined by exceeding shock threshold (could be config by SHOCK_THRESHOLD registers), for Y-axis
45	2D	3	None	1	Y_TEMPERATURE_X10		int16	Temperature = TEMPERATURE_X10 divide by 10, for Y-axis
46	2E	3	None	2	Y_SCALE_FACTOR_A		float	Scale factor A for velocity and acceleration values, for Y-axis
48	30	3	None	2	Y_SENSOR_SENSITIVITY		float	Sensor sensitivity, unit of mV/g, for Y-axis
50	32	3	None	2	Y_SHOCK_THRESHOLD		float	Shock threshold to detect/count shock event, unit of G, for Y-axis
52	34	3	None	2	Z_VELOCITY_RMS_A		float	RMS Velocity of band A, unit of mm/s, for Z-axis
54	36	3	None	2	Z_ACCELERATION_RMS_B		float	RMS Acceleration of band B, unit of m/s <sup>2</sup> , for Z-axis
56	38	3	None	2	Z_CREST_FACTOR_B		float	Crest factor of band B, for Z-axis
58	3A	3	None	2	Z_KURTOSIS_B		float	Kurtosis factor of band B, for Z-axis
60	3C	3	None	2	Z_ACCELERATION_PEAK_C		float	Peak Acceleration of band B, unit of m/s <sup>2</sup> , for Z-axis

62	3E	3	None	2	Z_CREST_FACTOR_C		float	Crest factor of band C, for Z-axis
64	40	3	None	2	Z_KURTOSIS_C		float	Kurtosis factor of band C, for Z-axis
66	42	3	None	1	Z_SHOCK_COUNT		uint16	Counter for shock events captured, a shock event is determined by exceeding shock threshold (could be config by SHOCK_THRESHOLD registers), for Z-axis
67	43	3	None	1	Z_TEMPERATURE_X10		int16	Temperature = TEMPERATURE_X10 divide by 10, for Z-axis
68	44	3	None	2	Z_SCALE_FACTOR_A		float	Scale factor A for velocity and acceleration values, for Z-axis
70	46	3	None	2	Z_SENSOR_SENSITIVITY		float	Sensor sensitivity, unit of mV/g, for Z-axis
72	48	3	None	2	Z_SHOCK_THRESHOLD		float	Shock threshold to detect/count shock event, unit of G, for Z-axis
74	4A	3	None	1	DEBUG_I2C_ERROR		hex	I2C read error code. 0: No error. 1: Error.
75	4B	3	None	196	spare		hex	spare
271	10F	3	16	2	X_CONFIG_SCALE_FACTOR		float	Configuration of SCALE_FACTOR_A, for X-axis
273	111	3	16	2	X_CONFIG_SENSOR_SENS		float	Configuration of sensor sensitivity, unit of mV/g, for X-axis
275	113	3	16	2	X_CONFIG_SHOCK_THRES		float	Configuration of shock threshold to detect/count shock event, unit of G, for X-axis
277	115	3	16	2	Y_CONFIG_SCALE_FACTOR		float	Configuration of SCALE_FACTOR_A, for Y-axis
279	117	3	16	2	Y_CONFIG_SENSOR_SENS		float	Configuration of sensor sensitivity, unit of mV/g, for Y-axis
281	119	3	16	2	Y_CONFIG_SHOCK_THRES		float	Configuration of shock threshold to detect/count shock event, unit of G, for Y-axis
283	11B	3	16	2	Z_CONFIG_SCALE_FACTOR		float	Configuration of SCALE_FACTOR_A, for Z-axis
285	11D	3	16	2	Z_CONFIG_SENSOR_SENS		float	Configuration of sensor sensitivity, unit of mV/g, for Z-axis
287	11F	3	16	2	Z_CONFIG_SHOCK_THRES		float	Configuration of shock threshold to detect/count shock event, unit of G, for Z-axis

## 7. Installation

- Create a hole on the installation surface with depth  $\geq$  6mm and thread M6x1.0
- Install the sensor to the hole using provided bolt



## 8. Calibration

The delivered sensor should be factory-calibrated. If customer would like to re-calibrate, please follow below process

### 8.1 Calibration preparation

- V3A sensor
- Axis Y/ Z calibration support fixture.
- A vibration calibrator with an M6 threaded mounting slot, capable of delivering standard 10 mm/s velocity RMS at 80Hz under a minimum 500g load.
- Modbus/RS485 to USB cable
- 7-48 VDC power supply
- Modbus Master Log software/application
- PC

### 8.2 Calibration setup

1. Connect sensor's RS485 port to the PC
2. Connect PWR+, PWR- to 7-48VDC power supply
3. Open Modbus Master Log software/application on PC
4. Configure the baud rate of 115200 bps, parity of none for the software/application for Modbus communication
5. Configure parameters to read are X\_SENSOR\_SENSITIVITY, X\_VELOCITY\_RMS\_A, Y\_SENSOR\_SENSITIVITY, Y\_VELOCITY\_RMS\_A, Z\_SENSOR\_SENSITIVITY, Z\_VELOCITY\_RMS\_A with Modbus function of 3

### 8.3 X/Y/Z axis calibration

#### 8.3.1 X axis calibration

1. Install the sensor to the vibration calibrator with provided bolt
2. Set the vibration calibrator to output a steady reference signal of 80Hz at standard 10 mm/s velocity RMS.
3. Log about 30 values of X\_VELOCITY\_RMS\_A parameters
4. Calculate the average value of X\_VELOCITY\_RMS\_A
5. Calculate  $X\_CONFIG\_SENSOR\_SENSITIVITY = X\_SENSOR\_SENSITIVITY * standard\ RMS\ velocity\ (10\ mm/s) /$

(average value of X\_VELOCITY\_RMS\_A in step 4).

6. Write calculated X\_CONFIG\_SENSOR\_SENSITIVITY to the sensor with Modbus function of 16
7. Re-read the X\_VELOCITY\_RMS\_A parameters. The value should be standard RMS velocity (10 mm/s)
8. Power off the vibration calibrator and unmount the sensor from the calibrator.

### 8.3.2 Y axis calibration

1. Secure the sensor onto the Axis Y/Z calibration support fixture then bolt the entire assembly back onto the calibrator on the target Y axis
2. Set the vibration calibrator to output a steady reference signal of 80Hz at standard 10 mm/s velocity RMS.
3. Log about 30 values of Y\_VELOCITY\_RMS\_A parameters
4. Calculate the average value of Y\_VELOCITY\_RMS\_A
5. Calculate  $Y\_CONFIG\_SENSOR\_SENSITIVITY = Y\_SENSOR\_SENSITIVITY * \text{standard RMS velocity (10 mm/s)} /$   
(average value of Y\_VELOCITY\_RMS\_A in step 4).
6. Write calculated Y\_CONFIG\_SENSOR\_SENSITIVITY to the sensor with Modbus function of 16
7. Re-read the Y\_VELOCITY\_RMS\_A parameters. The value should be standard RMS velocity (10 mm/s)
8. Power off the vibration calibrator and unmount the sensor from the calibrator.

### 8.3.3 Z axis calibration

1. Secure the sensor onto the Axis Y/Z calibration support fixture then bolt the entire assembly back onto the calibrator on the target Z axis
2. Set the vibration calibrator to output a steady reference signal of 80Hz at standard 10 mm/s velocity RMS.
3. Log about 30 values of Z\_VELOCITY\_RMS\_A parameters
4. Calculate the average value of Z\_VELOCITY\_RMS\_A
5. Calculate  $Z\_CONFIG\_SENSOR\_SENSITIVITY = Z\_SENSOR\_SENSITIVITY * \text{standard RMS velocity (10 mm/s)} /$   
(average value of Z\_VELOCITY\_RMS\_A in step 4).
6. Write calculated Z\_CONFIG\_SENSOR\_SENSITIVITY to the sensor with Modbus function of 16
7. Re-read the Z\_VELOCITY\_RMS\_A parameters. The value should be standard RMS velocity (10 mm/s)
8. Power off the vibration calibrator and unmount the sensor from the calibrator.

## 9. Support contacts



No.11 Street 2G, Nam Hung Vuong Res., An Lac Ward, Binh Tan Dist., Ho Chi Minh City, Vietnam.  
Tel: +84-28-6268.2523/4 (ext.122)  
Email: [support@daviteq.com](mailto:support@daviteq.com) | <https://www.iot.daviteq.com/>